

Troubleshooting tips

PROBLEM

SOLUTION

Too little material being discharged

1. Check air pressure and adjust. Remember optimum pressure is between 70-90 psi
2. Check length of pickup tube
3. Check viscosity of material...it may need thinning.
4. Check for obstructions in pickup tube, wand or air inlet hole in sprayhead.
5. Check that the spray tip is large enough for the material

Too much material being discharged

1. Reduce air pressure
2. Make sure material is not too thin

Irregular Spray Pattern

1. As above, check for obstructions in pickup tube, sprayhead, wands or inlet hole.
2. Check for foreign material or clots of material solids in canister.
3. Check functioning of air compressor.

Trigger on gun hard to pull

Apply small amount of silicone or oil around the valve (C-228-C) at hex nut (BB-104)

Limited 90 Day Warranty

Subject to terms and conditions set forth in this limited one-year warranty, manufacturer warrants this product to be free from defects in material or workmanship. This warranty does not include damage resulting from accident, abuse or misuse of the product nor does it apply to parts subject to normal wear. This warranty assumes no modification to the unit after manufacture. The manufacture assumes no liability for consequential damages of any nature, including but not limited to accidental application to various portions of vehicle. This warranty is in lieu of any other warranty or obligation including warranty of merchantability and/or fitness expressed or implied with no



Tri-Con
 442 South Green Road
 South Euclid, OH 44121
 Phone:(216) 496-2419 Fax:(216) 486-3530
 Email: triconsprayers@yahoo.com
 Website: triconsprayers.com



America's Most Durable Spraying Equipment

**Tri-Con M-1600-2
 1Qt Plastic Jar
 Siphon Spraying System
 Operation Manual
 DO NOT DISCARD!**

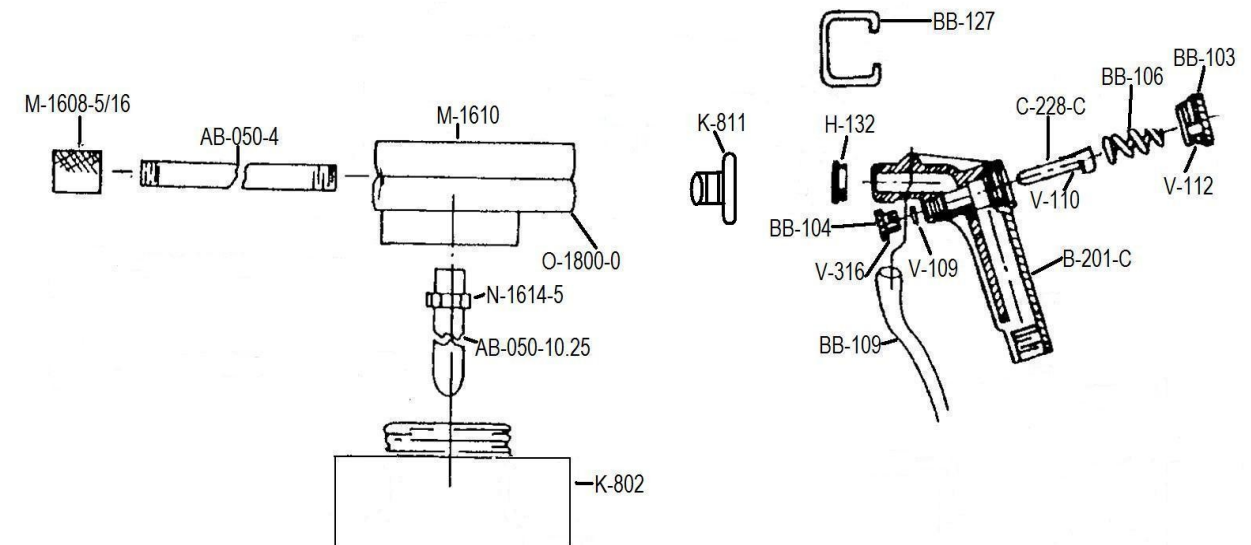

Sprayhead Components M-1610

M-1610	Body
K-803	Lid
K-811	Extender
AB-050-7.25	Pickup Tube
N-1614	Jam Nut
AB-050-4	Spray Wand
1608	Spray Tip

Optional

R-6855-3	Gauge & Regulator
V-1633-WRK	O-Ring Repair Kit

Air Blow Gun Components

F-C-210-N	Air Blow Gun Complete
B-201-C	Body
BB-103	Retainer Cap
BB-104	Gland Nut
BB-105	Trigger
BB-106	Spring
BB-127	Lock Ring
C--228-C	Valvestem
V-109	Valvestem O-Ring
V-110	Valve O-Ring
V-112	Retainer Cap Washer
V-316	Washer Instert

M-1600-2 is a Siphon Sprayer to spray thick heavy material such as truck bed liner material or for applying thicker coating to a surface that can not be accomplished by a conventional sprayer.

Assembly Instructions

1. F-C-210-N Air Gun
2. M-1610 Assembly
3. AB-050-4 Spray Wand
4. M-1608 Spray Tips 5/16" Silver(M-1608-S)

You will need...

- **IMPORTANT:** A pair of safety goggles and an approved respiratory mask
- Air Compressor
- Air supply hose to run from compressor to F-C-210-N air gun (hose needs 1/4" NPT threads to attach to air gun)
- A well ventilated area

To Assemble

1. Attach the sprayhead assembly to the air gun by screwing the swivel nut onto the nozzle end of the gun
2. Attach the spray wand onto the sprayhead assembly at the discharge end...hand tighten only.
3. Select the desired spray tip and screw it onto the end of the spray wand.
4. Attach a container of material to the sprayhead assembly by screwing the top of the container onto the aluminum lid.
5. Attach an air hose to the air gun

Operation

IMPORTANT: Follow recommended preparation and safety precautions.

1. Before spraying, make sure that the canister is tightly threaded to the sprayhead assembly, but do not force!
2. The unit operates between 40-120 psi with an optimum pressure between 70-90 psi.
- 3. Before changing containers, always disconnect the air hose!**
4. Keep the spray wand pointed toward the surface to be sprayed. Never point the spray gun at yourself or anyone else!
5. Always clean your M-1600-2 after each use.

Tips for more effective spraying

Make sure that areas that are not to be sprayed are covered or masked

Material of different viscosities will spray at different rates. Be sure to experiment with the three tips to determine which is best suited for your application

The force of the spray and the amount of atomization can be controlled by adjusting the air pressure.

Remember to move the M-1600-2 spray applicator back and forth in steady smooth strokes for even coverage.

Since viscous materials are affected by climate and age, follow manufacturer's instructions regarding storage, shelf life and thinning.

You are now ready to begin using your M-1600-2 spraying applicator

Maintaining your M-1600-2

Your 1600 is a quality product. With proper care, it will give you excellent performance for a long time.

1. After disconnecting the air line, refill with diluted mixture of solvent. When using solvents, be sure to follow the cautions on the solvent container. Also, because strong solvents will shorten the life of seals and O-rings, dilute the agent, following the advice of the solvent manufacturer.
2. Reconnect the canister and spray the cleaning solution through the unit and all used wands for 30 seconds.
3. Should air leaks develop in the gun, adjust the packing nut (BB-104) directly below the trigger or the retainer cap (BB-103) at the back of the gun.
4. To assure smooth operation of the trigger, occasionally spray silicone or oil around the valve mechanism of the spray gun.